



C2232M (2/07) **PMCL-VA Monitor** **Ceiling Mount Adapter**

Important Safety Instructions

1. Read these instructions.
2. Keep these instructions.
3. Heed all warnings.
4. Follow all instructions.
5. Installation should be done only by qualified personnel and conform to all local codes.
6. Only use replacement parts recommended by Pelco.
7. This unit is designed for indoor use only, and it must not be installed where exposed to rain or moisture.

Description

The PMCL-VA monitor mount adapter allows a Pelco PMCL-CM or PMCL-CMP ceiling mount to be used with certain Pelco PMCL500 Series flat panel LCD monitors. The adapter makes the ceiling mount VESA®-compliant. The adapter is required for the following Pelco monitors if they are ceiling mounted:

PMCL537	37-inch flat panel LCD monitor
PMCL542	42-inch flat panel LCD monitor

Installation

The following parts are supplied:

Qty	Description
1	Adapter plate
4	M6 x 12 machine screws

NOTE: It is recommended that at least two people be present when mounting the monitor. One person (or more) should hold the monitor, while a second (or third) person installs the screws to secure the monitor to the adapter plate.

INSTALLING THE CEILING MOUNT

Refer to the appropriate Pelco mount manual for details on installing the PMCL-CM (non-telescoping) ceiling mount, or installing and adjusting the PMCL-CMP (telescoping) ceiling mount. Do the following:

1. Attach the mount to the ceiling.
2. Adjust the length of the telescoping pole (PMCL-CMP only).
3. Adjust the lower section of the mount to the desired direction.

ATTACHING THE ADAPTER PLATE

Refer to Figure 1. To attach the PMCL-VA to the ceiling mount, do the following:

1. Position the adapter plate so the recessed square in the middle fits over the mounting head of the ceiling mount.
2. Use the 4 screws (supplied with the PMCL-VA adapter) to secure the adapter plate to the monitor mount.

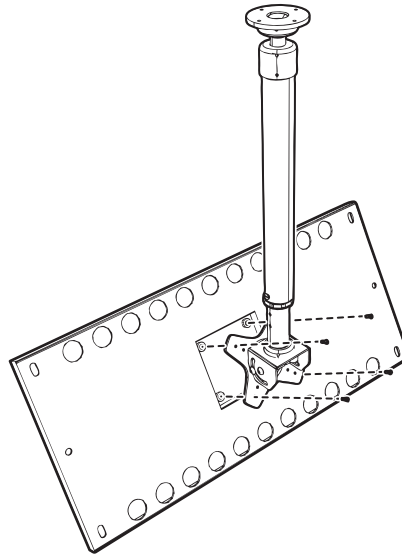

Figure 1. Attaching the PMCL-VA Adapter to the Ceiling Mount

ATTACHING THE MONITOR

NOTE: It is recommended that at least two people be present when mounting the monitor. One person (or more) should hold the monitor while a second (or third) person installs the screws to secure the monitor to the adapter plate. A lift, if available, can be used to help support the monitor's weight.

1. Refer to Figure 2. Remove the 6 screws from the back of the monitor.

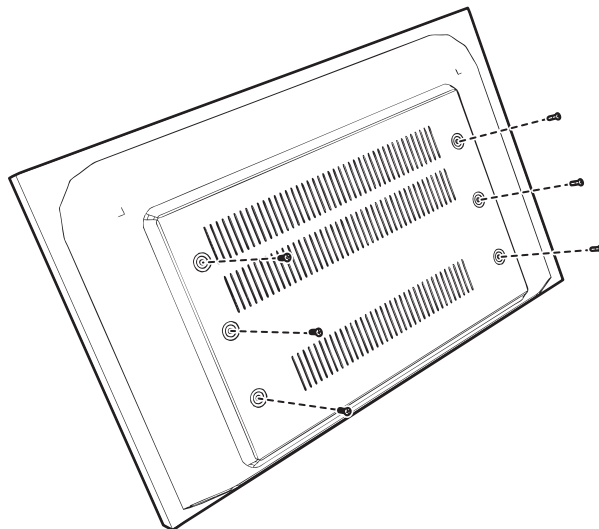

Figure 2. Removing the Screws from the Monitor

2. Hold the monitor level with the adapter plate.
3. Refer to Figure 3. Align the holes on the sides of the adapter plate with the holes on the back of the monitor. Install the screws removed in step 1 to secure the monitor to the adapter plate.

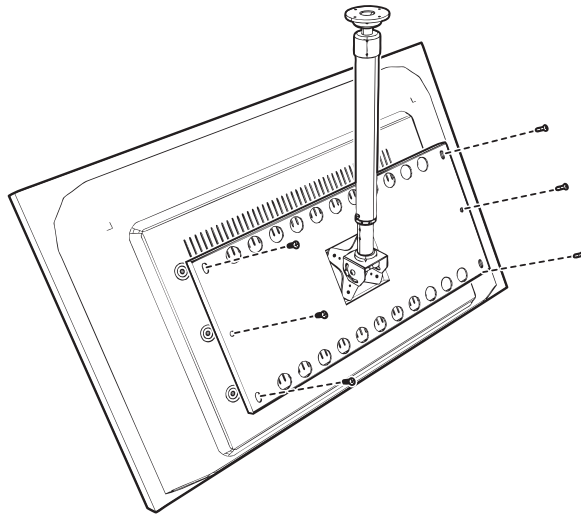

Figure 3. Attaching the Monitor to the Adapter Plate

CONNECTING POWER AND ADJUSTING TILT/SWIVEL

Refer to the appropriate Pelco mount manual for details. Do the following:

1. Position the power and video wires.
2. Tilt the monitor to the desired angle.
3. If desired, swivel the monitor between the portrait and landscape view.

Specifications

GENERAL

Suggested Mounting Method	Secure to ceiling mount using M6 x 12 machine screws (provided)
Construction	Steel
Finish	Black powder coat
Dimensions	Refer to Figure 4
Unit Weight	9.20 lb (4.17 kg)
Shipping Weight	11 lb (4.98 kg)

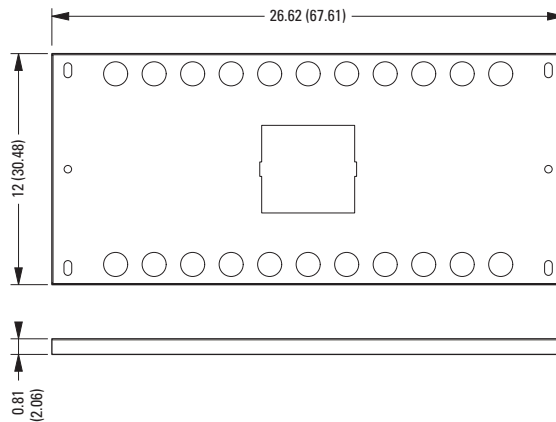

NOTE: VALUES IN PARENTHESIS ARE CENTIMETERS; ALL OTHERS ARE INCHES

Figure 4. PMCL-VA Dimension Drawing

PRODUCT WARRANTY AND RETURN INFORMATION

WARRANTY

Pelco will repair or replace, without charge, any merchandise proved defective in material or workmanship **for a period of one year** after the date of shipment.

Exceptions to this warranty are as noted below:

- Five years on fiber optic products and TW3000 Series unshielded twisted pair transmission products.
- Three years on Spectra® IV products.
- Three years on Genex® Series products (multiplexers, server, and keyboard).
- Three years on Camclosure® and fixed camera models, except the CC3701H-2, CC3701H-2X, CC3751H-2, CC3651H-2X, MC3651H-2, and MC3651H-2X camera models, which have a five-year warranty.
- Three years on PMCL200/300/400 Series LCD monitors.
- Two years on standard motorized or fixed focal length lenses.
- Two years on Legacy®, CM6700/CM6800/CM9700 Series matrix, and DF5/DF8 Series fixed dome products.
- Two years on Spectra III™, Esprit®, ExSite®, and PS20 scanners, including when used in continuous motion applications.
- Two years on Esprit and WW5700 Series window wiper (excluding wiper blades).
- Two years (except lamp and color wheel) on Digital Light Processing (DLP®) displays. The lamp and color wheel will be covered for a period of 90 days. The air filter is not covered under warranty.
- Eighteen months on DX Series digital video recorders, NVR300 Series network video recorders, and Endura™ Series distributed network-based video products.
- One year (except video heads) on video cassette recorders (VCRs). Video heads will be covered for a period of six months.
- Six months on all pan and tilts, scanners or preset lenses used in continuous motion applications (that is, preset scan, tour and auto scan modes).

Pelco will warrant all replacement parts and repairs for 90 days from the date of Pelco shipment. All goods requiring warranty repair shall be sent freight prepaid to Pelco, Clovis, California. Repairs made necessary by reason of misuse, alteration, normal wear, or accident are not covered under this warranty.

Pelco assumes no risk and shall be subject to no liability for damages or loss resulting from the specific use or application made of the Products. Pelco's liability for any claim, whether based on breach of contract, negligence, infringement of any rights of any party or product liability, relating to the Products shall not exceed the price paid by the Dealer to Pelco for such Products. In no event will Pelco be liable for any special, incidental or consequential damages (including loss of use, loss of profit and claims of third parties) however caused, whether by the negligence of Pelco or otherwise.

The above warranty provides the Dealer with specific legal rights. The Dealer may also have additional rights, which are subject to variation from state to state.

If a warranty repair is required, the Dealer must contact Pelco at (800) 289-9100 or (559) 292-1981 to obtain a Repair Authorization number (RA), and provide the following information:

1. Model and serial number
2. Date of shipment, P.O. number, Sales Order number, or Pelco invoice number
3. Details of the defect or problem

If there is a dispute regarding the warranty of a product which does not fall under the warranty conditions stated above, please include a written explanation with the product when returned.

Method of return shipment shall be the same or equal to the method by which the item was received by Pelco.

RETURNS

In order to expedite parts returned to the factory for repair or credit, please call the factory at (800) 289-9100 or (559) 292-1981 to obtain an authorization number (CA number if returned for credit, and RA number if returned for repair).

All merchandise returned for credit may be subject to a 20% restocking and refurbishing charge.

Goods returned for repair or credit should be clearly identified with the assigned CA or RA number and freight should be prepaid. Ship to the appropriate address below.

If you are located within the continental U.S., Alaska, Hawaii or Puerto Rico, send goods to:

Service Department
Pelco
3500 Pelco Way
Clovis, CA 93612-5699

If you are located outside the continental U.S., Alaska, Hawaii or Puerto Rico and are instructed to return goods to the USA, you may do one of the following:

If the goods are to be sent by a COURIER SERVICE, send the goods to:

Pelco
3500 Pelco Way
Clovis, CA 93612-5699 USA

If the goods are to be sent by a FREIGHT FORWARDER, send the goods to:

Pelco c/o Expeditors
473 Eccles Avenue
South San Francisco, CA 94080 USA
Phone: 650-737-1700
Fax: 650-737-0933

 The materials used in the manufacture of this document and its components are compliant to the requirements of Directive 2002/95/EC.

REVISION HISTORY

Manual #	Date	Comments
C2232M	2/07	Original version.

Pelco, the Pelco logo, Camclosure, Esprit, Genex, Legacy, ExSite, and Spectra are registered trademarks of Pelco.
Endura is a trademark of Pelco.
DLP is a registered trademark of Texas Instruments, Inc.
VESA is a registered trademark of the Video Electronics Standards Association

© Copyright 2007, Pelco. All rights reserved.



Worldwide Headquarters • 3500 Pelco Way • Clovis, California 93612 USA • www.pelco.com

USA & Canada • Tel: 800/289-9100 • Fax: 800/289-9150

International • Tel: 1-559/292-1981 • Fax: 1-559/348-1120